

General Safety Information:

- Do not shut / open hinged doors with excessive force.
- Install door stop to prevent door from opening too far.
- When installing glass panels ensure that all staff is properly qualified and trained.
- Always wear protective clothing when mounting glass panels.
- Always allow and adjust for sufficient panel clearances so that the glass does not touch other parts such as metal, glass and concrete.
- Always use the required correct torque force when tightening mounting screws.
- Avoid creating local stress areas. Do not over tighten mounting screws. Do not use excessive force.

Installation:

Frame Attachment:

IMPORTANT: DO NOT USE COUNTERSUNK CSK SCREWS FOR THE HINGE-TO-FRAME ATTACHMENT.

- Attach the hinge to the frame first.
- Always use standard washers for M8 screws.
- Always use standard M8 Hex Bolts or standard Hex-Cap-Socket Screws.
- Always tighten screws properly (12Nm (9ft-lb)).
- Always ensure that the frame structure is of suitable material & strength.

Door Attachment:

- Attach door panel after the hinge has been mounted to the frame
 - Ensure that the door mount flanges are horizontal when attaching to the door panel.
 - Ensure that both hinges are properly attached to the door panel before removing the support /lifting gear.
 - All hinges are supplied in the mid range adjustment position.
 - When adjusting the door panel height wind out the top height adjustment screws on both hinges before raising the panel height by winding in the bottom height adjustment screws on both hinges.
 - When adjusting the door panel height adjust both top and bottom hinge to ensure the load/weight is being shared equally by both hinges.
 - After the door has been height adjusted wind back in the top adjustment screws on both hinges.
- IMPORTANT: USE ONLY VERY SLIGHT FORCE (1 NM / 0.8 FT-LB). DO NOT OVER TIGHTEN THE TOP HEIGHT ADJUSTMENT SCREWS WHEN THE BOTTOMING OUT POSITION HAS BEEN REACHED.**
- Check all the hinges and fittings at regular intervals for correct positioning and adjustment.
 - Use properly trained staff to inspect/ maintain the proper condition of hinged doors especially for frequently opened/closed panels.

Tools Required for Hinge Adjustment:

-11 mm Open-Ended Spanner



-4mm Hex / Allen Key (Preferably Ball-Nose)



Torque

Recommended Tightening torque settings for screws:

- Monolithic, tempered (single panel) glass door = 12Nm (9ft-lb)
- Laminated tempered (multiple panels) glass door = 12Nm (9ft-lb)
- Countersunk CSK glass screws = 12Nm (9ft-lb)
- Frame mount bolts = 12Nm (9ft-lb) if possible - depending on frame material

Manfred Frank Systems recommend using thread locking compound whenever possible.

ATTENTION

Do not use Countersunk CSK Screws for the hinge-to-frame attachment.

Always use a M8 Washer on both frame mount holes.

We recommend installing door stops to prevent doors opening too far.

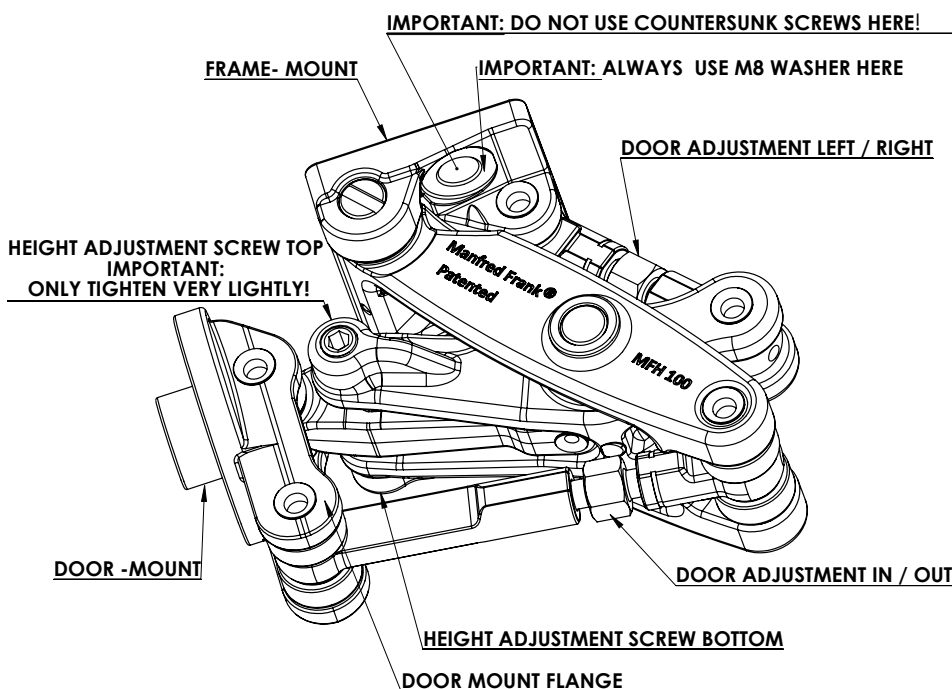

Need Help?

For more detailed instructions go to www.manfredfrank.com or send an email to info@manfredfrank.com

Disclaimer of Liability:

Since the conditions or methods of installation, operation, use and maintenance of this product are beyond its control, Manfred Frank Systems Limited does not assume responsibility and expressly disclaims liability of loss, damage, or expense arising out of or in any way connected with such installation, operation, use, or maintenance.

DOOR INSERT GUIDE

Routing Guides:

FOR PANEL THICKNESS FROM
 32mm(1.25") TO 51mm(2")

DOOR PANEL CUT OUT DETAILS FOR D50 & D51 DOOR MOUNTS

IMPORTANT: Please reference the cut out depth from the top panel surface.
 Ensure that the cut out depth is exact and does not change with panel thickness variations.

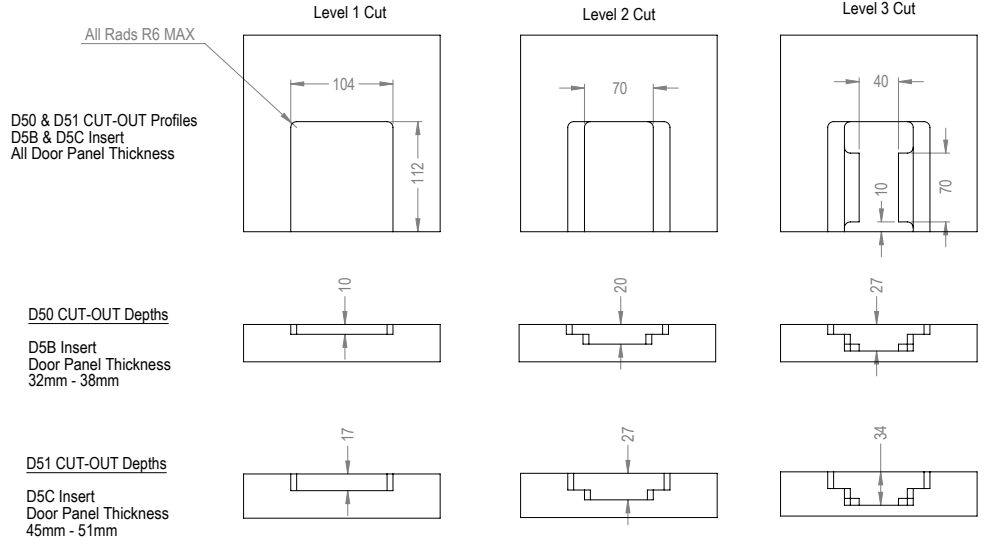
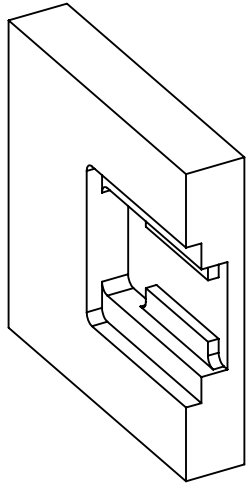

ADDITIONAL DETAILS FOR OVERLAY END DOOR PANEL CUT OUT FOR D50 & D51 DOOR MOUNTS

IMPORTANT: Please reference the cut out depth from the top panel surface.
 Ensure that the cut out depth is exact and does not change with panel thickness variations.

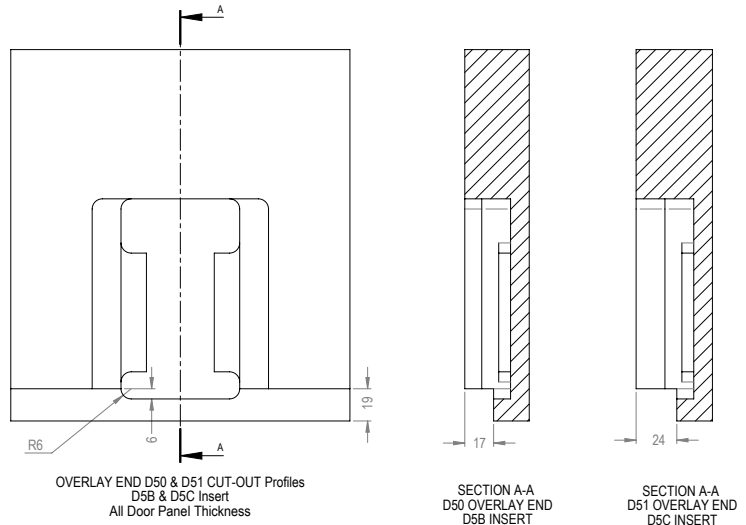
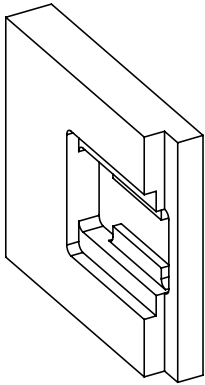

Installation:

IMPORTANT:
 ALWAYS USE WASHERS HERE
 DO NOT USE COUNTESUNK SCREWS

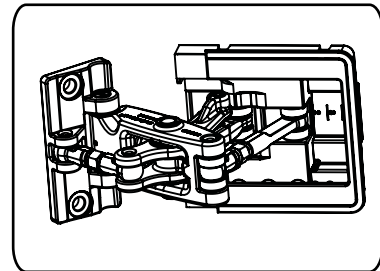
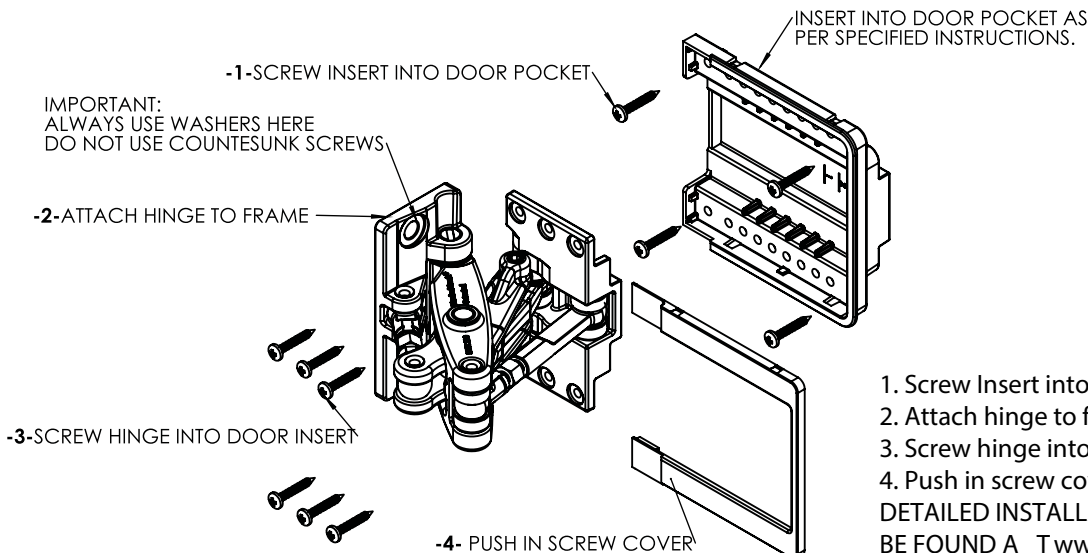

1. Screw Insert into door pocket
2. Attach hinge to frame
3. Screw hinge into door insert
4. Push in screw cover

DETAILED INSTALLATION INSTRUCTIONS CAN
 BE FOUND AT www.manfredfrank.com